



**Street Corn Lamp**

## LED Turtle Friendly Corn 15W

**Models:**

CL-15W-XX (CL/FR)-T AC100-277V 600nm-605nm  
Amber Color

**Product Features:**

- ◇ IP64 rated, dustproof, insect proof, Clear or Frosted Cover
- ◇ No Fan design, internal driver, aluminum driver box, heat-conducting glue covered driver
- ◇ With a IC temperature control inside, also no stroboflash
- ◇ Can be used in fully sealed fixture
- ◇ Certificate: UL, cUL, CE, RoHS
- ◇ 50000 hours lifespan, 5 years warranty

### Dimensions

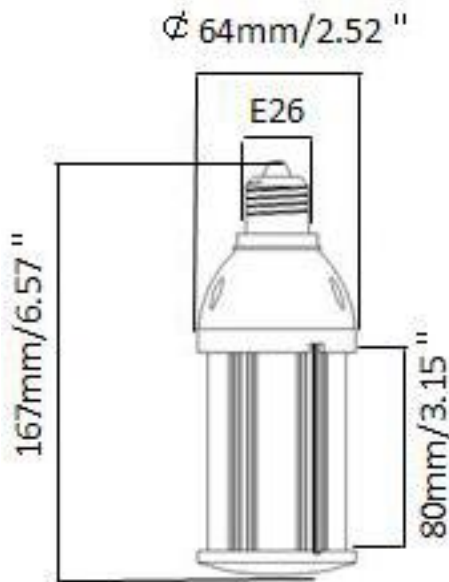

### Wildlife Lighting Certification

**Number: 2018-022**



<p><b>Omnidirectional</b></p> <p>360° Illumination</p>	<p><b>Suitable</b></p> <p>For Enclosed Luminaires</p>	<p><b>Solid State</b></p> <p>Vibration and Shock Resistant</p>	<p><b>Reliability</b></p> <p>LM-80 Tested ISTMT Tested</p>	<p><b>Lumen Efficacy</b></p> <p>140 lpw LM-79 Tested</p>	<p><b>Warranty</b></p> <p>5 years Safe and Reliable</p>	<p><b>Sustainability</b></p> <p>Environmentally Friendly</p>
--	---	--	--	--	---	--

## Technical Specifications

<b>Model</b>	<b>CL-15W-XX(CL/FR)-T</b>
<b>Rate Power</b>	<b>15W±5%</b>
<b>Input Voltage</b>	<b>AC100-277V 50/60Hz</b>
<b>Light Color</b>	<b>Amber Color</b>
<b>Wavelength</b>	<b>600nm-605nm</b>
<b>Power Factor</b>	<b>&gt;0.9</b>
<b>Lumens</b>	<b>220lm±5%</b>
<b>Lighting Source</b>	<b>LED 2835SMD</b>
<b>Operating Temp.</b>	<b>-20~45°C</b>
<b>Mounting</b>	<b>E26 E27</b>
<b>Rated Life</b>	<b>Up to 50,000 Hrs.</b>
<b>LED LM80</b>	<b>Yes</b>

## Applications



## Installations

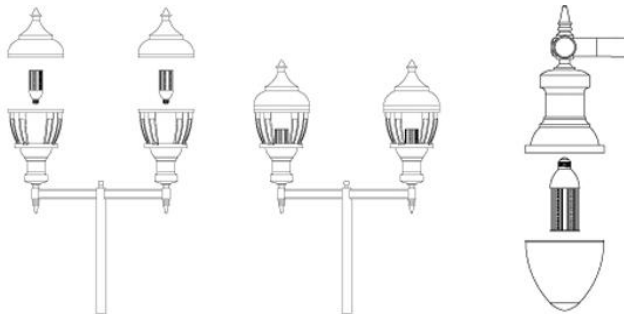

Street Lighting / Acorn

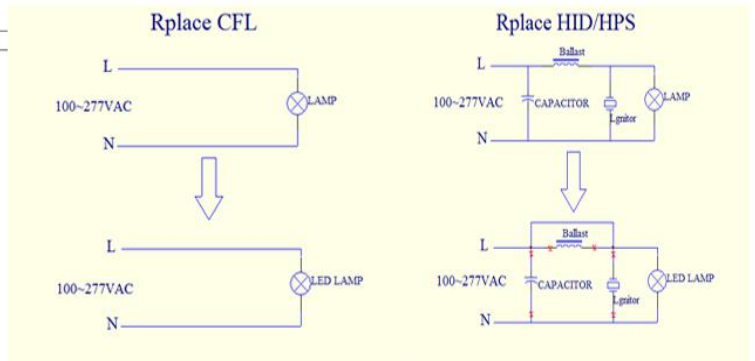

## Packing Details

<b>Pack Quantity</b>	<b>25PCS/Carton</b>
<b>Net Weight Per CTN</b>	<b>0.75lbs/340g</b>
<b>Gross Weight Per CTN</b>	<b>24.69lbs/11.2kg</b>
<b>Inner Box Size</b>	<b>2.95"x2.95"x 7.68"</b>
<b>Master Carton Size</b>	<b>15.9"x 15.9"x 9"</b>

