

Cypress Lighting Technologies



LED Turtle Friendly Corn 30W

Models:

CL-30W-CL-T AC100-277V 600nm-605nm Amber Color

Product Features:

- ◇ IP64 rated, dustproof, insect proof
- ◇ No Fan design, internal driver, aluminum driver box, heat-conducting glue covered driver
- ◇ With a IC temperature control inside, also no stroboflash
- ◇ Can be used in fully sealed fixture
- ◇ Certificate: UL, cUL, CE, RoHS
- ◇ 50000 hours lifespan, 5 years warranty

Dimensions

Wildlife Lighting Certification

Number: 2018-022

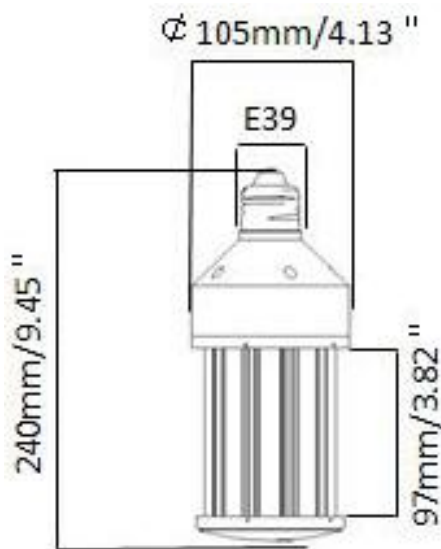

<p>Omnidirectional</p> <p>360° Illumination</p>	<p>Suitable</p> <p>For Enclosed Luminaires</p>	<p>Solid State</p> <p>Vibration and Shock Resistant</p>	<p>Reliability</p> <p>LM-80 Tested ISTMT Tested</p>	<p>Lumen Efficacy</p> <p>140 lpw LM-79 Tested</p>	<p>Warranty</p> <p>5 years</p> <p>Safe and Reliable</p>	<p>Sustainability</p> <p>Environmentally Friendly</p>
--	---	--	--	--	--	--

Tel: 985-817-9100
www.cypresslightingtech.com

Cypress Lighting Technologies, LLC

Skype: cypresslightingtech
Email: info@cypresslightingtech.com

PO Box 912
Robert, Louisiana 70455

Technical Specifications

Model	CL-30W-CL-T
Rate Power	30W±5%
Input Voltage	AC100-277V 50/60Hz
Light Color	Amber Color
Wavelength	600nm-605nm
Power Factor	>0.9
Lumens	500lm±5%
Lighting Source	LED 2835SMD
Operating Temp.	-20~45°C
Mounting	E26 E27 E39 E40
Rated Life	Up to 50,000 Hrs.
LED LM80	Yes

Applications



Installations



Street Lighting / Acorn

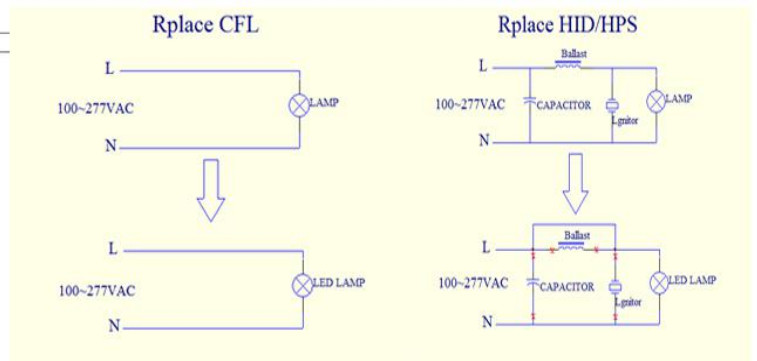

Packing Details

Pack Quantity	8PCS
Net Weight Per CTN	2.31lbs/1050g
Gross Weight Per CTN	24.25lbs/11kg
Inner Box Size	11.2" x 5.7" x 5.9"
Master Carton Size	25.6" x 13.8" x 12.4"

