

Cypress Lighting Technologies



LED Turtle Friendly Corn 60W

Models:

CL-60W-CL-T AC100-277V 600nm-605nm Amber Color

Product Features:

- ◇ IP64 rated, dustproof, insect proof
- ◇ No Fan design, internal driver, aluminum driver box, heat-conducting glue covered driver
- ◇ With a IC temperature control inside, also no stroboflash
- ◇ Can be used in fully sealed fixture
- ◇ Certificate: UL, cUL, CE, RoHS
- ◇ 50000 hours lifespan, 5 years warranty

Dimensions

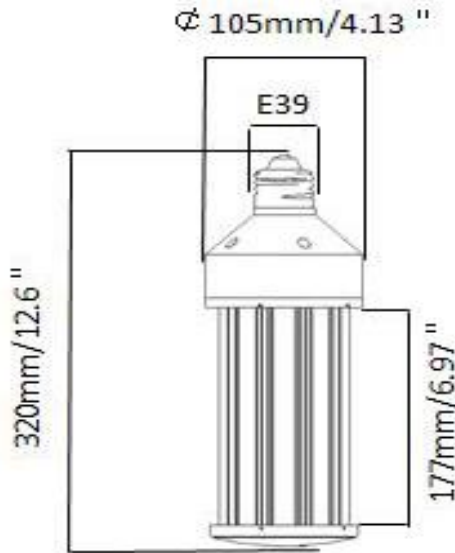

Wildlife Lighting Certification

Number: 2018-022



<p>Omnidirectional</p> <p>360° Illumination</p>	<p>Suitable</p> <p>For Enclosed Luminaires</p>	<p>Solid State</p> <p>Vibration and Shock Resistant</p>	<p>Reliability</p> <p>LM-80 Tested ISTMT Tested</p>	<p>Lumen Efficacy</p> <p>140 lpw LM-79 Tested</p>	<p>Warranty</p> <p>5 years</p> <p>Safe and Reliable</p>	<p>Sustainability</p> <p>Environmentally Friendly</p>
--	---	--	--	--	--	--

Tel: 985-817-9100
www.cypresslightingtech.com

Cypress Lighting Technologies, LLC

Skype: cypresslightingtech
Email: info@cypresslightingtech.com

PO Box 912
Robert, Louisiana 70455

Technical Specifications

Model	CL-60W-CL-T
Rate Power	60W±5%
Input Voltage	AC100-277V 50/60Hz
Light Color	Amber Color
Wavelength	600nm-605nm
Power Factor	>0.9
Lumens	1050lm±5%
Lighting Source	LED SMD5730
Operating Temp.	-20~45°C
Mounting	E26/E27/E39/E40
Rated Life	Up to 50,000 Hrs.
LED LM80	Yes

Applications



Installations

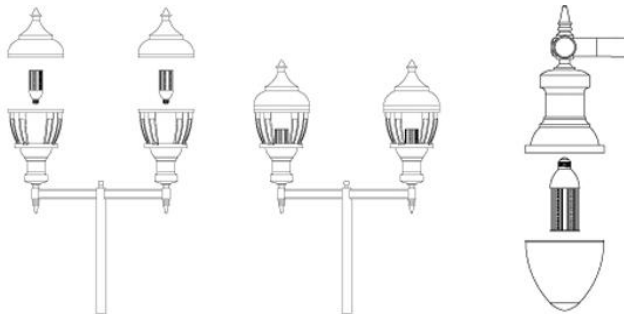

Street Lighting / Acorn

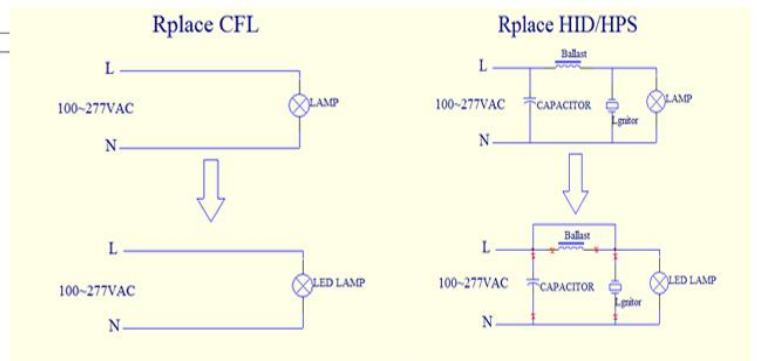

Packing Details

Pack Quantity	8PCS
Net Weight Per CTN	2.65lbs/1200g
Gross Weight Per CTN	27.51lbs/12.48kg
Inner Box Size	14.4" x 5.7" x 5.9"
Master Carton Size	25.6" x 13.8" x 15.6"

